



Attributes

Highlights	Description
<ul style="list-style-type: none"> ▪ High repeatability ▪ Zero backlash with optimised fit between speed and resolution ▪ Preloaded ball bearing ▪ Extreme dynamic ▪ Lifetime lubrication 	<p>High angular resolution combined with dynamics and high speeds characterise the MaalonDrive® HighRes 10mm - type 3. The combination of a zero-backlash MaalonDrive® gear with a reduction ratio of 160:1 with an EC motor with rated voltage of 12V and an integrated encoder with a resolution of 256 pulses per rotation results in a high-performance micro positioning system. The output shaft is precisely guided by preloaded ball bearings which allow the application to be directly connected.</p>

Technical parameter

The stated values are based on calculations and measurements by Micromotion GmbH, carried out according to the current state of the art. You can find our definitions at www.micromotion-drives.com. For further information please contact sales@micromotion.de.

P-019

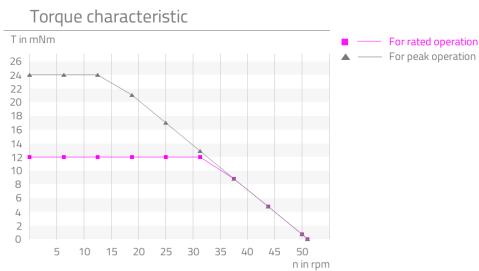

P-029

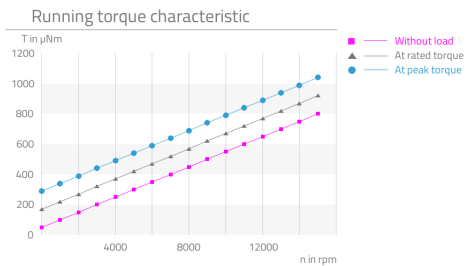

Technical Supply Specifications: MaalonDrive® HighRes 10mm - Type 3



Micromotion GmbH, Phone: +49 (0) 6431 – 569 18 – 25, E-mail: sales@micromotion.de

Nr.	Parameter	Symbol	Value	Hint
P-003	Ratio	i	160 : 1	
P-004	Self-locking		yes	
P-008	Repeatability unidirectional		10 arcsec	
P-009	Repeatability bidirectional		20 arcmin	
P-010	Accuracy		15 arcmin	
P-011	Transmission accuracy		30 arcmin	
P-012	Resolution		0.00879 °	
P-013	Torsional stiffness		9.30 ^{Nm} /rad	
P-014	Lost motion		20 arcmin	
P-015	Backlash		0 arcmin	
P-016	Rated torque	T	12 mNm	
P-017	Peak torque	T	24 mNm	
P-018	Momentary peak torque	T	55 mNm	
P-021	Rated input speed	n	10000 rpm	
P-022	Maximum input speed	n	30000 rpm	
P-023	Rated output speed	n	62.5 rpm	
P-024	Maximum output speed	n	187.5 rpm	
P-026	No-load starting torque	T	75 µNm	
P-027	No-load running torque	T	50 µNm	
P-028	Rated running torque	T	670 µNm	
P-034	Lifetime for rated operation		1000 h	
P-035	Radial backlash output shaft		0 µm	
P-036	Axial backlash output shaft		0 µm	
P-037	Radial stiffness	c	2.3 N/µm	
P-038	Axial stiffness	c	40 ^N /µm	
P-039	Max. radial load on output shaft (non-operating, constant load)	F	55 N	
P-040	Max. radial load on output shaft (non-operating, impulsive load)	F	20 N	
P-041	Max. radial load on output shaft (operating, constant load)	F	7 N	
P-042	Max. radial load on output shaft (operating, impulsive load)	F	7 N	
P-043	Max. axial load on output shaft (non-operating, constant load)	F	150 N	
P-044	Max. axial load on output shaft (non-operating, impulsive load)	F	50 N	

Technical Supply Specifications: MaalonDrive® HighRes 10mm - Type 3



Micromotion GmbH, Phone: +49 (0) 6431 – 569 18 – 25, E-mail: sales@micromotion.de

Nr.	Parameter	Symbol	Value	Hint
P-045	Max. axial load on output shaft (operating, constant load)	F	380 N	
P-046	Max. axial load on output shaft (operating, impulsive load)	F	127 N	
P-055	Moment of inertia	I	$113.3 \cdot 10^{-4}$ gcm ²	
P-056	Weight	m	8 g	
P-057	Min. permissible ambient temperature (non-operating)	T	-20 °C	
P-058	Min. permissible ambient temperature (operating)	T	-20 °C	
P-059	Max. permissible ambient temperature (non-operating)	T	125 °C	
P-060	Max. permissible ambient temperature (operating)	T	100 °C	

Motor data: EC-Motor EC 6 1.5W 12V

(Data are provided by the manufacturer or are based on the data sheets of the manufacturer)

Nr.	Parameter	Symbol	Value	Hint
P-100	Motortype		EC	
P-102	Maximum speed of motor	n	100000 rpm	
P-104	Speed constant of motor	Kn	3040 $\frac{\text{rpm}}{\text{V}}$	
P-106	Stall torque of motor	T	0.59 mNm	
P-107	Torque constant of motor	Km	3.14 $\frac{\text{mNm}}{\text{A}}$	
P-108	No-load current of motor	I	16.2 mA	
P-110	Max. continuous current of motor	I	116 mA	
P-111	Rated voltage of motor	U	12 V	
P-112	Phase resistance of motor	R	63.8 ohm	
P-113	Inductance of motor	L	0.436 mH	
P-114	Amplitude BEMF of motor	U	0.329 mV/rpm	
P-118	Max. coil temperature of motor	T	125 °C	
P-119	Thermal resistance of motor between coil and housing	R _{th1}	16.8 $\frac{\text{K}}{\text{W}}$	
P-120	Thermal resistance of motor between housing and air	R _{th2}	67.1 $\frac{\text{K}}{\text{W}}$	
P-121	Thermal time constant of the coil of the motor	T _{w1}	1690 ms	
P-122	Thermal time constant of the housing of the motor	T _{w2}	71800 ms	

Technical Supply Specifications: MaalonDrive® HighRes 10mm - Type 3



Micromotion GmbH, Phone: +49 (0) 6431 – 569 18 – 25, E-mail: sales@micromotion.de

Encoder data

(Data are provided by the manufacturer or are based on the data sheets of the manufacturer)

Nr.	Parameter	Symbol	Value	Hint
P-200	Type of encoder		Incremental	
P-201	Impulses per revolution of encoder		256	
P-202	Channels of encoder		A, B, I	
P-203	Frequency range of encoder	f	500 kHz	
P-204	Operating voltage of encoder	U	3.3 ±0.3 V	
P-205	Rated current consumption of encoder	I	13 mA	
P-206	Output current of encoder	I	4 mA	
P-207	Signal/phase shifting of encoder		90±45 °	
P-208	Signal build-up/decay time of encoder	t	0.010 ms	

Material information

Nr.	Parameter	Symbol	Value	Hint
P-900	RoHS compliant		yes	
P-901	Lubrication of output bearing gearbox		Longtime PD2	
P-903	Lubrication of gear component set		Molykote BR 2 plus	
P-908	Material of gear component set		NiFe	
P-909	Material of output bearing gearbox		1.4108 DIN EN	
P-911	Material of bearing motor		Stainless steel	
P-912	Material of gearbox output side		1.4305 DIN EN	
P-914	Material of motor housing		Steel, black coated	

Technical Supply Specifications: MaalonDrive® HighRes 10mm - Type 3



Micromotion GmbH, Phone: +49 (0) 6431 – 569 18 – 25, E-mail: sales@micromotion.de

Technical drawing

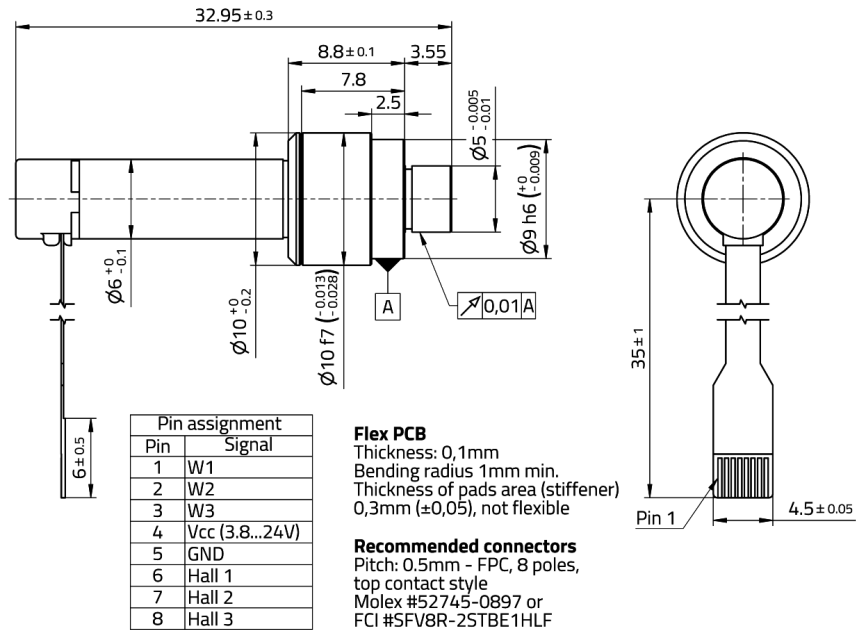

Micromotion GmbH | Hoenbergstraße 14 | 65555 Limburg
+49(0)6431-59618-25 | sales@micromotion.de | www.micromotion-drives.com