



Attributes

Highlights	Description
<ul style="list-style-type: none">▪ High adjustment speed▪ Integrated flexure hinges▪ Easy controllability▪ Connecting cable assembled▪ Resolution in the range of nm	<p>The KeevoDrive® HighAcc 10mm - type 4 micro positioning system combines an eccentric input system with flexure hinge kinematics, thereby allowing outstanding accuracy in the linearity of the movements to be realised. The flexure hinge kinematics consists of the elements of the linear guides and, in addition, feature customer-specific fastening structures for connecting the application and the positioning system. The combination of a low-backlash CoograDrive® gear with a reduction ratio of 40:1 with an EC motor with rated voltage of 6V and an integrated encoder with a resolution of 1024 pulses per rotation results in an especially high-performance micro positioning system. An optical linear encoder with a resolution of 0.2 µm is integrated additionally for position control.</p>

Technical parameter

The stated values are based on calculations and measurements by Micromotion GmbH, carried out according to the current state of the art. You can find our definitions at www.micromotion-drives.com.

For further information please contact sales@micromotion.de.

P-005

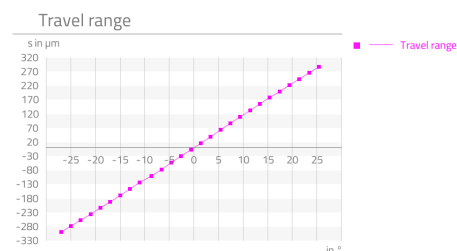

P-016

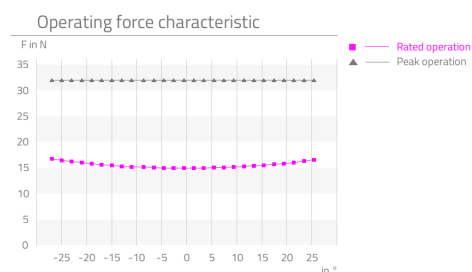

P-502

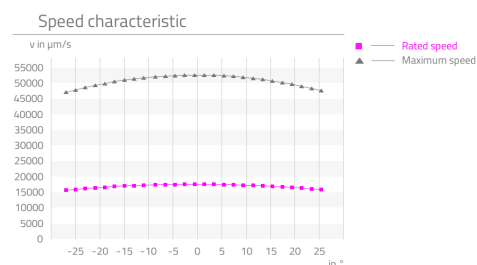

P-512

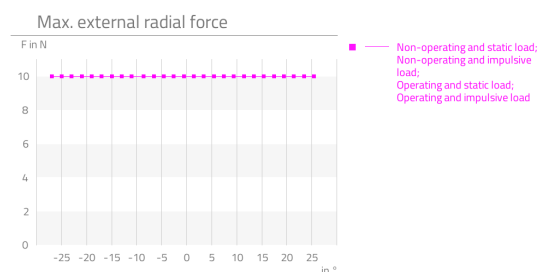

Nr.	Parameter	Symbol	Value	Hint
P-003	Ratio	i	40 : 1	
P-004	Self-locking		yes	
P-005	Max. travel range	s	600 µm	
P-008	Repeatability unidirectional		0.1 µm	
P-009	Repeatability bidirectional		0.3 µm	
P-010	Accuracy		5 µm	
P-015	Backlash		0 µm	
P-016	Rated force	F	14.9254 N	
P-017	Peak force	F	119.403 N	
P-018	Momentary peak force	F	149.254 N	
P-034	Lifetime for rated operation		1000 h	
P-035	Radial backlash output shaft		0 µm	
P-036	Axial backlash output shaft		0 µm	

Technical Supply Specifications: KeevoDrive® HighAcc 10mm - Type 4



Micromotion GmbH, Phone: +49 (0) 6431 – 569 18 – 25, E-mail: sales@micromotion.de

Nr.	Parameter	Symbol	Value	Hint
P-037	Radial stiffness	c	11.32 N/μm	
P-038	Axial stiffness	c	40 ^N /μm	
P-039	Max. radial load on output shaft (non-operating, constant load)	F	135 N	
P-040	Max. radial load on output shaft (non-operating, impulsive load)	F	45 N	
P-041	Max. radial load on output shaft (operating, constant load)	F	32 N	
P-042	Max. radial load on output shaft (operating, impulsive load)	F	32 N	
P-043	Max. axial load on output shaft (non-operating, constant load)	F	150 N	
P-044	Max. axial load on output shaft (non-operating, impulsive load)	F	50 N	
P-045	Max. axial load on output shaft (operating, constant load)	F	380 N	
P-046	Max. axial load on output shaft (operating, impulsive load)	F	127 N	
P-055	Moment of inertia	I	660.03 * 10 ⁻⁶ gcm ²	
P-056	Weight	m	375 g	
P-057	Min. permissible ambient temperature (non-operating)	T	-40 °C	
P-058	Min. permissible ambient temperature (operating)	T	-20 °C	
P-059	Max. permissible ambient temperature (non-operating)	T	125 °C	
P-060	Max. permissible ambient temperature (operating)	T	100 °C	

Additional technical data:

- Operating environment: max. inadmissible stroke +/- 500 (-0/+40) μm
- stroke bijectively detected by limit sensors: +/- 410 μm

Motor data: EC-Motor 1028S006B

(Data are provided by the manufacturer or are based on the data sheets of the manufacturer)

Nr.	Parameter	Symbol	Value	Hint
P-100	Motortype		EC	
P-102	Maximum speed of motor	n	79000 rpm	1)
P-104	Speed constant of motor	Kn	5426 ^{rpm} /V	
P-106	Stall torque of motor	T	9.72 mNm	
P-107	Torque constant of motor	Km	1.76 ^{mNm} /A	
P-108	No-load current of motor	I	121 mA	

Technical Supply Specifications: KeevoDrive® HighAcc 10mm - Type 4



Micromotion GmbH, Phone: +49 (0) 6431 – 569 18 – 25, E-mail: sales@micromotion.de

Nr.	Parameter	Symbol	Value	Hint
P-110	Max. continuous current of motor	I	1160 mA	2)
P-111	Rated voltage of motor	U	6 V	
P-112	Phase resistance of motor	R	1.08 ohm	
P-113	Inductance of motor	L	0.024 mH	
P-114	Amplitude BEMF of motor	U	0.184 mV/rpm	
P-118	Max. coil temperature of motor	T	125 °C	
P-119	Thermal resistance of motor between coil and housing	R _{th1}	6.6 ^{°C} /W	1)
P-120	Thermal resistance of motor between housing and air	R _{th2}	42.4 ^{°C} /W	
P-121	Thermal time constant of the coil of the motor	T _{w1}	4200 ms	1)
P-122	Thermal time constant of the housing of the motor	T _{w2}	152000 ms	

Encoder data

(Data are provided by the manufacturer or are based on the data sheets of the manufacturer)

Nr.	Parameter	Symbol	Value	Hint
P-202	Channels of encoder		A, A-, B, B-, I, I-	
P-203	Frequency range of encoder	f	8000 kHz	
P-204	Operating voltage of encoder	U	5 ±0.5 V	
P-205	Rated current consumption of encoder	I	150 mA	

Excenter data

Nr.	Parameter	Symbol	Value	Hint
P-501	Eccentricity		670 µm	
P-504	Max. radial load on eccentric bearing (non-operating, constant load)	F	119.403 N	
P-505	Max. radial load on eccentric bearing (non-operating, impulsive load)	F	45 N	
P-506	Max. radial load on eccentric bearing (operating, constant load)	F	32 N	
P-507	Max. radial load on eccentric bearing (operating, impulsive load)	F	32 N	
P-508	Max. axial load on eccentric bearing (non-operating, constant load)	F	150 N	
P-509	Max. axial load on eccentric bearing (non-operating, impulsive load)	F	50 N	

Technical Supply Specifications: KeevoDrive® HighAcc 10mm - Type 4



Micromotion GmbH, Phone: +49 (0) 6431 – 569 18 – 25, E-mail: sales@micromotion.de

Nr.	Parameter	Symbol	Value	Hint
P-510	Max. axial load on eccentric bearing (operating, constant load)	F	380 N	
P-511	Max. axial load on eccentric bearing (operating, impulsive load)	F	127 N	
P-513	Eccentricity error		20 µm	

Data flexure hinges

(Data are provided by the manufacturer or are based on the data sheets of the manufacturer)

Nr.	Parameter	Symbol	Value	Hint
P-701	Flexure hinge ratio	i	1	
P-702	Max. load on flexure hinges	F	10 N	
P-703	Angular position of eccentric at min. position	α	-26.6 °	
P-704	Angular position of eccentric at max. position	α	26.6 °	

Material information

Nr.	Parameter	Symbol	Value	Hint
P-900	RoHS compliant		yes	
P-901	Lubrication of output bearing gearbox		Longtime PD2/ Molykote BR 2 plus	
P-903	Lubrication of gear component set		Molykote BR 2 plus	
P-907	Lubrication of eccentric bearing		Longtime PD2	
P-908	Material of gear component set		NiFe	
P-909	Material of output bearing gearbox		1.4108 DIN EN	
P-912	Material of gearbox output side		1.4305 DIN EN	
P-914	Material of motor housing		Aluminium	
P-915	Material of eccentric bearing		1.4108 DIN EN	

2) Curve measured with nominal voltage and load inertia $6 \cdot 10^{-9} \text{ kg/m}^2$ in $\frac{1}{2}$ micro steps.

Technical Supply Specifications: KeevoDrive® HighAcc 10mm - Type 4



Micromotion GmbH, Phone: +49 (0) 6431 – 569 18 – 25, E-mail: sales@micromotion.de

Technical drawing

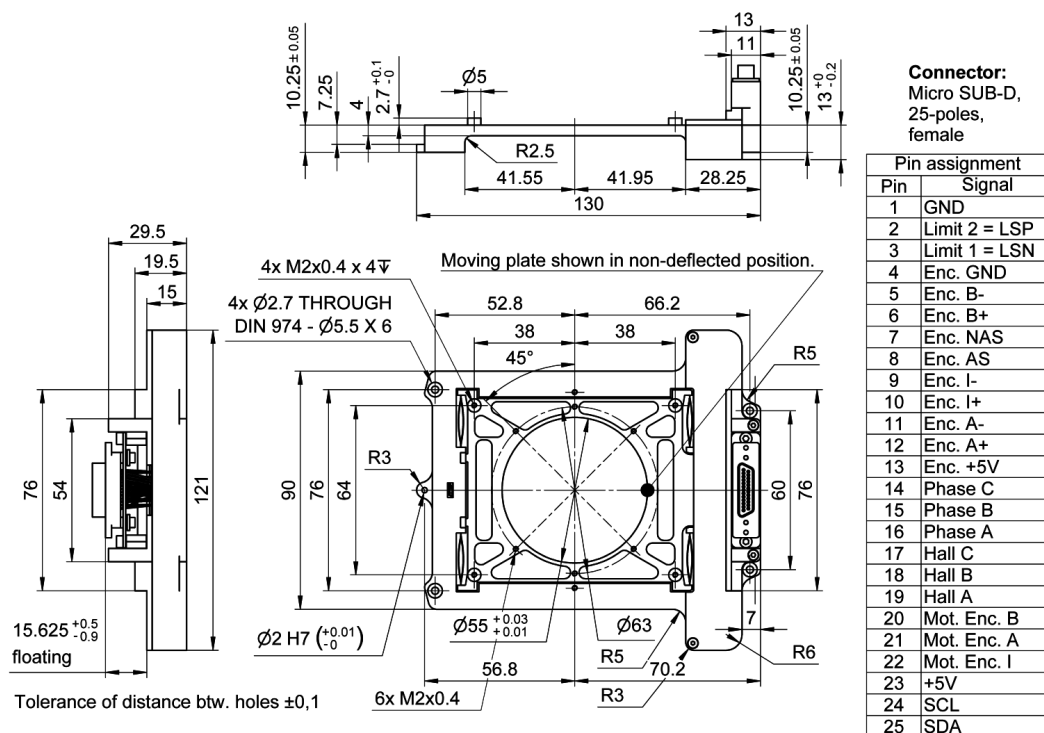

Micromotion GmbH | Hoenbergstraße 14 | 65555 Limburg
+49(0)6431-59618-25 | sales@micromotion.de | www.micromotion-drives.com