

> RasuunDrive®

HighSpeed 10mm - Type 7

Attributes

Highlights	Description
<ul style="list-style-type: none">▪ High adjustment speed▪ Integrated limit switches▪ Simple integration to the application▪ Adapter with cylindrical surface▪ Connecting cable and connector assembled	<p>The RasuunDrive® HighSpeed 10mm - type 7 micro positioning system has a linear travel range of 6 mm. The system is driven by a stepper motor with 20 steps per rotation. The immediately following drive train consists of a low-backlash CoograDrive® gear with a reduction ratio of 40:1 and a spring-loaded, zero-backlash spindle nut system with a pitch of 0.4 mm. Two magneto-resistive limit sensors monitor the end positions. The micro linear actuator system is attached by means of an M6x0.5 thread; the load is connected via an M3x3.5 thread.</p>

Technical parameter

The stated values are based on calculations and measurements by Micromotion GmbH, carried out according to the current state of the art. You can find our definitions at www.micromotion-drives.com.

For further information please contact sales@micromotion.de.

P-019 Curve measured with 5x nominal voltage and load inertia $6 \cdot 10^{-9} \text{ kg/m}^2$ in $\frac{1}{4}$ micro steps.

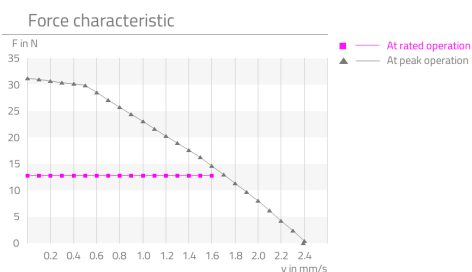

Nr.	Parameter	Symbol	Value	Hint
P-003	Ratio	i	40 : 1	
P-004	Self-locking		yes	
P-005	Travel range	s	6 mm	
P-008	Repeatability unidirectional		1 μm	
P-009	Repeatability bidirectional		5 μm	
P-010	Accuracy		12 μm	
P-012	Resolution		0.5 μm	
P-014	Lost motion		5 μm	
P-015	Backlash		0 μm	
P-016	Rated force	F	12.8106 N	
P-017	Peak force	F	50 N	
P-018	Momentary peak force	F	50 N	
P-021	Rated input speed	n	10000 rpm	
P-022	Maximum input speed	n	21000 rpm	
P-023	Rated speed	v	1.66667 $\frac{\text{mm}}{\text{s}}$	
P-024	Maximum speed	v	3.5 $\frac{\text{mm}}{\text{s}}$	
P-034	Lifetime for rated operation		1000 h	
P-035	Radial backlash output shaft		0 μm	
P-036	Axial backlash output shaft		0 μm	

Technical Supply Specifications: RasunDrive® HighSpeed 10mm - Type 7



Micromotion GmbH, Phone: +49 (0) 6431 – 569 18 – 25, E-mail: sales@micromotion.de

Nr.	Parameter	Symbol	Value	Hint
P-044	Max. axial load on output shaft (non-operating, impulsive load)	F	50 N	
P-055	Moment of inertia	I	$938.05 \cdot 10^{-4}$ gcm ²	
P-057	Min. permissible ambient temperature (non-operating)	T	-35 °C	
P-058	Min. permissible ambient temperature (operating)	T	-20 °C	
P-059	Max. permissible ambient temperature (non-operating)	T	130 °C	
P-060	Max. permissible ambient temperature (operating)	T	70 °C	

Motor data: Stepper AM 1020-2R-A0.25

(Data are provided by the manufacturer or are based on the data sheets of the manufacturer)

Nr.	Parameter	Symbol	Value	Hint
P-100	Motortype		Stepper	
P-102	Maximum speed of motor	n	21000 rpm	
P-103	Resonance frequency of motor	f	140 Hz	
P-105	Holding torque of motor (unpowered)	T	0.2 mNm	
P-109	Rated current of motor	I	250 mA	
P-111	Rated voltage of motor	U	2 V	
P-112	Phase resistance of motor	R	8 ohm	
P-113	Inductance of motor	L	2.4 mH	
P-114	Amplitude BEMF of motor	U	0.6 mV/rpm	
P-115	Full step angle of motor		18 °	
P-116	Angular accuracy of step of motor		±1.8 °	
P-117	Electrical time constant of motor	t	0.32 ms	
P-118	Max. coil temperature of motor	T	130 °C	
P-119	Thermal resistance of motor between coil and housing	R _{th1}	3.9 [°] /W	
P-120	Thermal resistance of motor between housing and air	R _{th2}	53.8 [°] /W	
P-121	Thermal time constant of the coil of the motor	τ _{w1}	3200 ms	
P-122	Thermal time constant of the housing of the motor	τ _{w2}	200000 ms	
P-123	Insulation voltage of motor	U	200 V	

Technical Supply Specifications: RasuunDrive® HighSpeed 10mm - Type 7



Micromotion GmbH, Phone: +49 (0) 6431 – 569 18 – 25, E-mail: sales@micromotion.de

Data limit switch

(Data are provided by the manufacturer or are based on the data sheets of the manufacturer)

Nr.	Parameter	Symbol	Value	Hint
P-302	Configuration Limit switches		n.c.	

Spindle data: Precision spindle m 2x0.4 – 6 mm travel range

(Data are provided by the manufacturer or are based on the data sheets of the manufacturer)

Nr.	Parameter	Symbol	Value	Hint
P-402	Pitch	R	0.4 mm	

Material information

Nr.	Parameter	Symbol	Value	Hint
P-900	RoHS compliant		yes	
P-901	Lubrication of output bearing gearbox		Longtime PD2	
P-903	Lubrication of gear component set		Molykote BR 2 plus	
P-904	Lubrication of bearing motor		Synthetic light ester oil	
P-905	Lubrication of spindel-nut-system		Fomblin GRM60	
P-908	Material of gear component set		NiFe	
P-909	Material of output bearing gearbox		1.4108 DIN EN	
P-911	Material of bearing motor		Stainless steel	
P-912	Material of gearbox output side		1.4305 DIN EN	
P-914	Material of motor housing		Anodized aluminum	
P-917	Material of spindle		1.4305 DIN EN	

Technical Supply Specifications: RasuuDrive® HighSpeed 10mm - Type 7



Micromotion GmbH, Phone: +49 (0) 6431 – 569 18 – 25, E-mail: sales@micromotion.de

Technical drawing

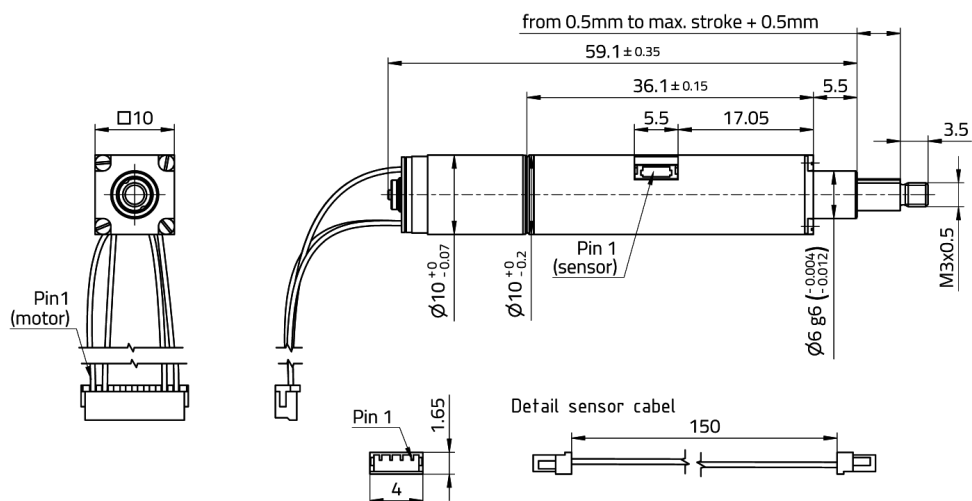

Pin assignment motor		
Pin	Signal	Color
1	Motor A+	Black
2	Motor B-	Orange
3	n.c.	-
4	n.c.	-
5	n.c.	-
6	n.c.	-
7	Motor A-	White
8	Motor B+	Blue

Cable (motor):
Individual lead wires
AWG 30, length=125mm

Recommended connectors (motor):
Header, Pitch: 1.5mm, 8 poles,
JST B8B-ZR or S8B-ZR

Pin assignment sensor	
Pin	Signal
1	LSN
2	GND
3	LSP
4	Vcc

connector (sensor):
Header, 4-pole, JST SM04B-SURS



Micromotion GmbH | Hoenbergstraße 14 | 65555 Limburg
+49(0)6431-59618-25 | sales@micromotion.de | www.micromotion-drives.com