



> RasuunDrive®

UHV 19mm - Type 3

Attributes

Highlights	Description
<ul style="list-style-type: none"> ▪ Vacuum suitable lubrication ▪ Use of high quality materials ▪ High axial load capacity ▪ Robust control without feedback system ▪ Adapter with cylindrical surface 	<p>The RasuunDrive® UHV 19mm - type 3 is using Braycote 601 EF for lubrication as it is especially designed for applications in ultrahigh-vacuum environments. It offers a travel range of 25.5 mm and is driven by a stepper motor with 200 steps per rotation in an open loop control. Directly connected to the motor is a low-backlash CoograDrive® gear with a reduction ratio of 40:1 by means of which a dry-lubricated ball-screw drive with a pitch of 0.5 mm is driven.</p>

Technical parameter

The stated values are based on calculations and measurements by Micromotion GmbH, carried out according to the current state of the art. You can find our definitions at www.micromotion-drives.com.
 For further information please contact sales@micromotion.de.

P-019

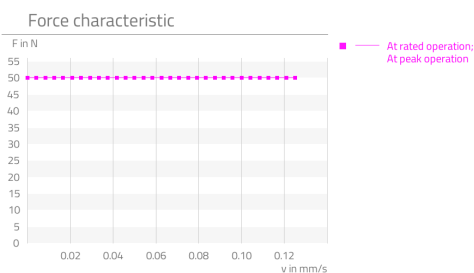

Technical Supply Specifications: RasuunDrive® UHV 19mm - Type 3



Micromotion GmbH, Phone: +49 (0) 6431 – 569 18 – 25, E-mail: sales@micromotion.de

Nr.	Parameter	Symbol	Value	Hint
P-001	Vacuum suitable		ultra high vacuum	
P-003	Ratio	i	40 : 1	
P-004	Self-locking		yes	
P-005	Travel range	s	25.5 mm	
P-008	Repeatability unidirectional		0.75 µm	
P-009	Repeatability bidirectional		3 µm	
P-010	Accuracy		20 µm	
P-012	Resolution		0.0625 µm	
P-014	Lost motion		7.5 µm	
P-015	Backlash		0.01 µm	
P-016	Rated force	F	50 N	
P-017	Peak force	F	50 N	
P-018	Momentary peak force	F	50 N	
P-023	Rated speed	v	0.20833 mm/s	
P-024	Maximum speed	v	0.20833 mm/s	
P-034	Lifetime for rated operation		300 h	
P-035	Radial backlash output shaft		0 µm	
P-036	Axial backlash output shaft		0 µm	
P-044	Max. axial load on output shaft (non-operating, impulsive load)	F	50 N	
P-055	Moment of inertia	I	900038 * 10 ⁻⁴ gcm ²	
P-057	Min. permissible ambient temperature (non-operating)	T	-20 °C	
P-058	Min. permissible ambient temperature (operating)	T	-10 °C	
P-059	Max. permissible ambient temperature (non-operating)	T	150 °C	
P-060	Max. permissible ambient temperature (operating)	T	120 °C	

Motor data: Stepper VSS 19.200.0,6-UHVG-2g5-BC-R

(Data are provided by the manufacturer or are based on the data sheets of the manufacturer)

Nr.	Parameter	Symbol	Value	Hint
P-100	Motortype		Stepper	
P-102	Maximum speed of motor	n	1000 rpm	
P-105	Holding torque of motor (unpowered)	T	0.9 mNm	

Technical Supply Specifications: RasunDrive® UHV 19mm - Type 3



Micromotion GmbH, Phone: +49 (0) 6431 – 569 18 – 25, E-mail: sales@micromotion.de

Nr.	Parameter	Symbol	Value	Hint
P-109	Rated current of motor	I	600 mA	
P-111	Rated voltage of motor	U	42 V	
P-112	Phase resistance of motor	R	2.1 ohm	
P-113	Inductance of motor	L	0.85 mH	
P-115	Full step angle of motor		1.8 °	
P-116	Angular accuracy of step of motor		±0.09 °	
P-117	Electrical time constant of motor	t	0.367 ms	
P-118	Max. coil temperature of motor	T	300 °C	1)

Data limit switch

(Data are provided by the manufacturer or are based on the data sheets of the manufacturer)

Nr.	Parameter	Symbol	Value	Hint
P-302	Configuration Limit switches		no limit switches	

Spindle data: Ball screw 1214./0,5.3.35.42r ts (uhv) – 25 mm travel range

(Data are provided by the manufacturer or are based on the data sheets of the manufacturer)

Nr.	Parameter	Symbol	Value	Hint
P-402	Pitch	R	0.5 mm	

Data linear bearing LSAGT8

(Data are provided by the manufacturer or are based on the data sheets of the manufacturer)

Nr.	Parameter	Symbol	Value	Hint
P-601	Max. lateral force in y-direction (non-operating, constant load)	F	1330 N	
P-602	Max. lateral force in y-direction (non-operating, impulsive load)	F	439 N	
P-603	Max. lateral force in y-direction (operating, constant load)	F	1190 N	
P-604	Max. lateral force in y-direction (operating, impulsive load)	F	396 N	
P-605	Max. lateral force in z-direction (non-operating, constant load)	F	1330 N	
P-606	Max. lateral force in z-direction (non-operating, impulsive load)	F	439 N	
P-607	Max. lateral force in z-direction (operating, constant load)	F	1190 N	

Technical Supply Specifications: RasunDrive® UHV 19mm - Type 3



Micromotion GmbH, Phone: +49 (0) 6431 – 569 18 – 25, E-mail: sales@micromotion.de

Nr.	Parameter	Symbol	Value	Hint
P-608	Max. lateral force in z-direction (operating, impulsive load)	F	396 N	
P-609	Max. overturning around y-axis (non-operating, constant load)	T	38300 mNm	
P-610	Max. overturning around y-axis (non-operating, impulsive load)	T	12639 mNm	
P-611	Max. overturning around y-axis (operating, constant load)	T	38300 mNm	
P-612	Max. overturning around y-axis (operating, impulsive load)	T	12639 mNm	
P-613	Max. overturning around z-axis (non-operating, constant load)	T	22000 mNm	
P-614	Max. overturning around z-axis (non-operating, impulsive load)	T	7260 mNm	
P-615	Max. overturning around z-axis (operating, constant load)	T	22000 mNm	
P-616	Max. overturning around z-axis (operating, impulsive load)	T	7260 mNm	
P-619	Stiffness in z-direction	c	28,7	
P-620	Backlash of linear guiding in y-direction		0 µm	
P-621	Backlash of linear guiding in z-direction		0 µm	

Material information

Nr.	Parameter	Symbol	Value	Hint
P-900	RoHS compliant		yes	
P-901	Lubrication of output bearing gearbox		Braycote601EF	
P-903	Lubrication of gear component set		Braycote601EF	
P-904	Lubrication of bearing motor		Braycote601EF	
P-905	Lubrication of spindel-nut-system		Braycote601EF	
P-906	Lubrication of linear bearing		Braycote601EF	
P-908	Material of gear component set		NiFe	
P-909	Material of output bearing gearbox		1.4108 DIN EN	
P-911	Material of bearing motor		Stainless steel	
P-912	Material of gearbox output side		1.4305 DIN EN	

Technical Supply Specifications: RasuunDrive® UHV 19mm - Type 3



Micromotion GmbH, Phone: +49 (0) 6431 – 569 18 – 25, E-mail: sales@micromotion.de

Nr.	Parameter	Symbol	Value	Hint
P-914	Material of motor housing		Stainless steel	
P-917	Material of spindle		1.4108 / CuSn	

Technical drawing

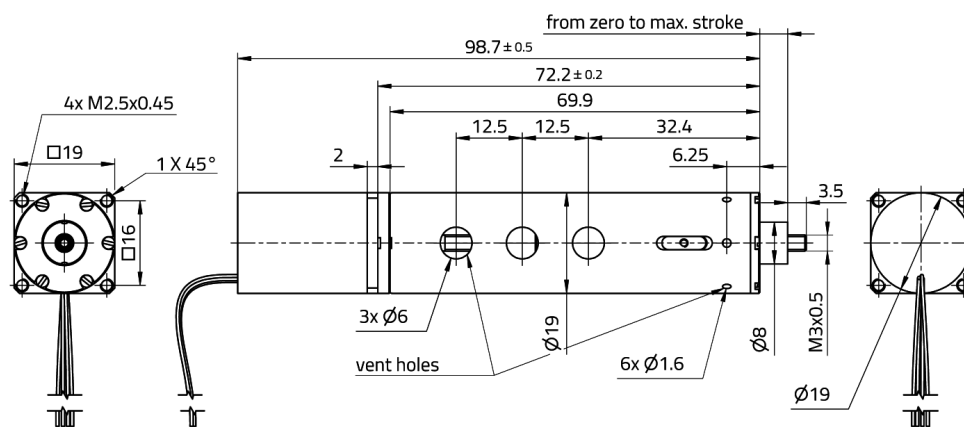

Pin assignment	
Color	Signal
YEL	A+
RED	A-
BLU	B+
GRE	B-

Cable:
4x Individual leads wires,
PTFE-insulating, AWG28,
length=300mm



Micromotion GmbH | Hoenbergstraße 14 | 65555 Limburg
+49(0)6431-59618-25 | sales@micromotion.de | www.micromotion-drives.com