



## Attributes

Highlights	Description
<ul style="list-style-type: none"><li>▪ <b>Integrated tool fitting</b></li><li>▪ <b>Integrated vacuum supply for tool</b></li><li>▪ <b>Zero backlash with optimised fit between speed and resolution</b></li><li>▪ <b>Sealed motor bearing</b></li><li>▪ <b>Preloaded ball bearing</b></li></ul>	<p>The MaalonDrive® ToolFit 10mm - type 9 micro servo actuator, with its extensive configuration, was designed as the ideal solution for precise pick-and-place applications. In a very small space, it combines a tool holder with clamping fixture in the output shaft, the index for referencing, a vacuum through-line for the tool, as well as robust stepper motor technology. In addition, the motor is covered in order to reliably avoid impairing the vacuum in the supply line. At the heart of the micro positioning system is a zero-backlash MaalonDrive® gear with a reduction ratio of 160:1. The flange on the housing allows the micro actuator to easily be integrated in the existing design.</p>

## Technical parameter

The stated values are based on calculations and measurements by Micromotion GmbH, carried out according to the current state of the art. You can find our definitions at [www.micromotion-drives.com](http://www.micromotion-drives.com).

For further information please contact [sales@micromotion.de](mailto:sales@micromotion.de).

P-019 Curve measured with 5x nominal voltage and load inertia  $6 \cdot 10E-9 \text{ kg/m}^2$  in  $\frac{1}{4}$  micro steps.

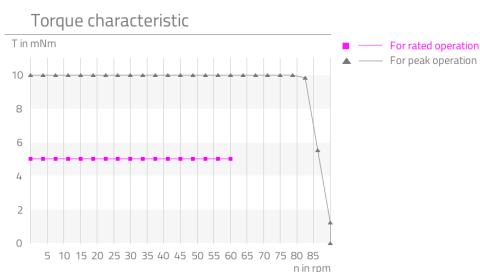

P-029 Curve measured with 5x nominal voltage and load inertia  $6 \cdot 10E-9 \text{ kg/m}^2$  in  $\frac{1}{4}$  micro steps.

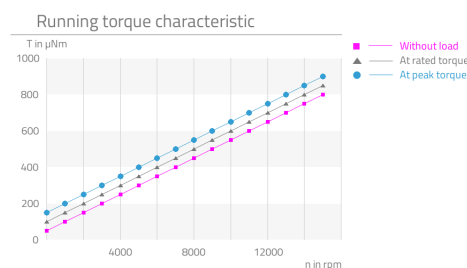

Nr.	Parameter	Symbol	Value	Hint
P-003	Ratio	i	160 : 1	
P-004	Self-locking		yes	
P-008	Repeatability unidirectional		35.25 arcsec	
P-009	Repeatability bidirectional		20.675 arcmin	
P-010	Accuracy		13.35 arcmin	
P-011	Transmission accuracy		26.7 arcmin	
P-012	Resolution		0.1125 °	
P-013	Torsional stiffness		8.25 $\frac{\text{Nm}}{\text{rad}}$	
P-014	Lost motion		12 arcmin	
P-015	Backlash		0 arcmin	
P-016	Rated torque	T	5 mNm	
P-017	Peak torque	T	10 mNm	
P-018	Momentary peak torque	T	23 mNm	
P-021	Rated input speed	n	10000 rpm	
P-022	Maximum input speed	n	21000 rpm	
P-023	Rated output speed	n	62.5 rpm	
P-024	Maximum output speed	n	131.25 rpm	
P-026	No-load starting torque	T	75 $\mu\text{Nm}$	
P-027	No-load running torque	T	50 $\mu\text{Nm}$	

# Technical Supply Specifications: MaalonDrive® ToolFit 10mm - Type 9



Micromotion GmbH, Phone: +49 (0) 6431 – 569 18 – 25, E-mail: sales@micromotion.de

Nr.	Parameter	Symbol	Value	Hint
P-028	Rated running torque	T	600 µNm	
P-034	Lifetime for rated operation		1000 h	
P-035	Radial backlash output shaft		0 µm	
P-036	Axial backlash output shaft		0 µm	
P-037	Radial stiffness	c	11.32 N/µm	
P-038	Axial stiffness	c	40 N/µm	
P-039	Max. radial load on output shaft (non-operating, constant load)	F	135 N	
P-040	Max. radial load on output shaft (non-operating, impulsive load)	F	45 N	
P-041	Max. radial load on output shaft (operating, constant load)	F	32 N	
P-042	Max. radial load on output shaft (operating, impulsive load)	F	32 N	
P-043	Max. axial load on output shaft (non-operating, constant load)	F	150 N	
P-044	Max. axial load on output shaft (non-operating, impulsive load)	F	50 N	
P-045	Max. axial load on output shaft (operating, constant load)	F	380 N	
P-046	Max. axial load on output shaft (operating, impulsive load)	F	127 N	
P-055	Moment of inertia	I	923 * 10 <sup>-4</sup> gcm <sup>2</sup>	
P-056	Weight	m	14 g	
P-057	Min. permissible ambient temperature (non-operating)	T	-35 °C	
P-058	Min. permissible ambient temperature (operating)	T	-20 °C	
P-059	Max. permissible ambient temperature (non-operating)	T	130 °C	
P-060	Max. permissible ambient temperature (operating)	T	70 °C	
P-061	Tool fitting		Ø3.17G5 – 8 deep	
P-062	Connecting for vacuum supply		Ø1.8 – 1 deep	

# Technical Supply Specifications: MaalonDrive® ToolFit 10mm - Type 9



Micromotion GmbH, Phone: +49 (0) 6431 – 569 18 – 25, E-mail: sales@micromotion.de

Additional technical data:

- magnetic index
- covered motor bearing at backside

## Motor data: Stepper AM 1020-2R-A0.25

(Data are provided by the manufacturer or are based on the data sheets of the manufacturer)

Nr.	Parameter	Symbol	Value	Hint
P-100	Motortype		Stepper	
P-102	Maximum speed of motor	n	21000 rpm	
P-103	Resonance frequency of motor	f	140 Hz	
P-105	Holding torque of motor (unpowered)	T	0.2 mNm	
P-109	Rated current of motor	I	250 mA	
P-111	Rated voltage of motor	U	2 V	
P-112	Phase resistance of motor	R	8 ohm	
P-113	Inductance of motor	L	2.4 mH	
P-114	Amplitude BEMF of motor	U	0.6 mV/rpm	
P-115	Full step angle of motor		18 °	
P-116	Angular accuracy of step of motor		±1.8 °	
P-117	Electrical time constant of motor	t	0.32 ms	
P-118	Max. coil temperature of motor	T	130 °C	
P-119	Thermal resistance of motor between coil and housing	R <sub>th1</sub>	3.9 <sup>K</sup> /W	
P-120	Thermal resistance of motor between housing and air	R <sub>th2</sub>	53.8 <sup>K</sup> /W	
P-121	Thermal time constant of the coil of the motor	T <sub>w1</sub>	3200 ms	
P-122	Thermal time constant of the housing of the motor	T <sub>w2</sub>	200000 ms	
P-123	Insulation voltage of motor	U	200 V	

## Material information

Nr.	Parameter	Symbol	Value	Hint
P-900	RoHS compliant		yes	
P-901	Lubrication of output bearing gearbox		Longtime PD2/ Molykote BR 2 plus	
P-903	Lubrication of gear component set		Molykote BR 2 plus	
P-904	Lubrication of bearing motor		Synthetic light ester oil	
P-908	Material of gear component set		NiFe	

# Technical Supply Specifications: MaalonDrive® ToolFit 10mm - Type 9



Micromotion GmbH, Phone: +49 (0) 6431 – 569 18 – 25, E-mail: sales@micromotion.de

Nr.	Parameter	Symbol	Value	Hint
P-909	Material of output bearing gearbox		1.4108 DIN EN	
P-911	Material of bearing motor		Stainless steel	
P-912	Material of gearbox output side		1.4305 DIN EN	
P-914	Material of motor housing		Anodized aluminum	

## Technical drawing

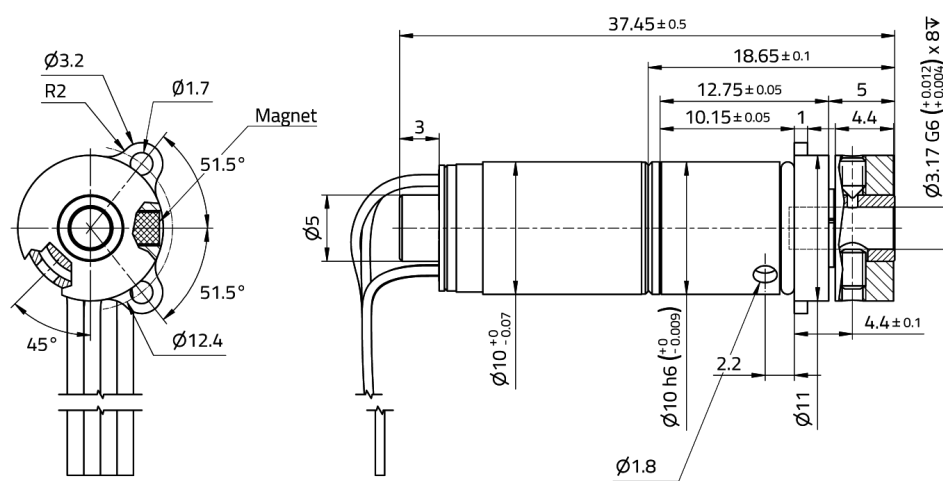

Pin assignment	
Pin	Signal
1	Motor A+
2	Motor A-
3	Motor B+
4	Motor B-

**cable:**  
high flexible ribbon cable,  
4 leads, AWG28,  
length=300mm,  
Pin 1 is labelled



Micromotion GmbH | Hoenbergstraße 14 | 65555 Limburg  
+49(0)6431-59618-25 | sales@micromotion.de | www.micromotion-drives.com